

ATK-CLIMX93B1

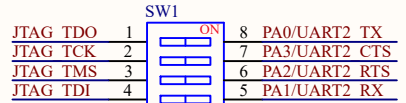
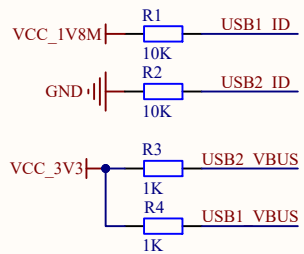
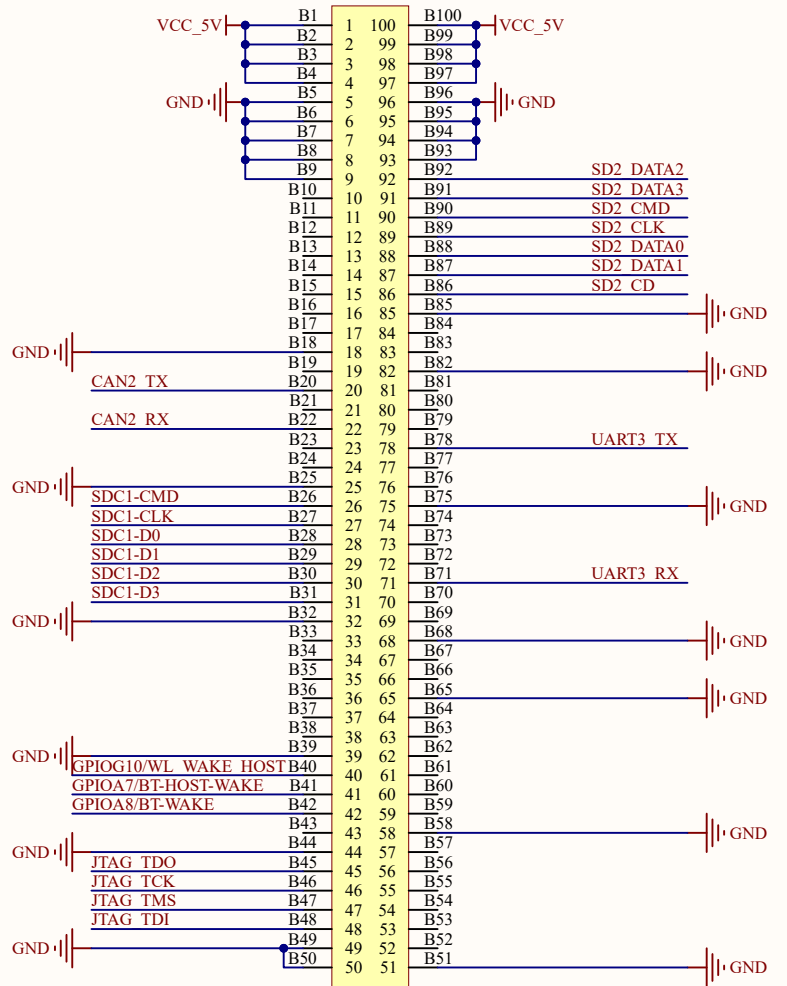
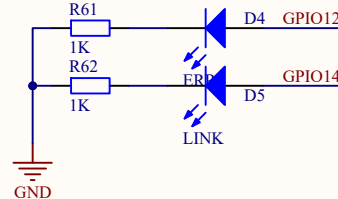
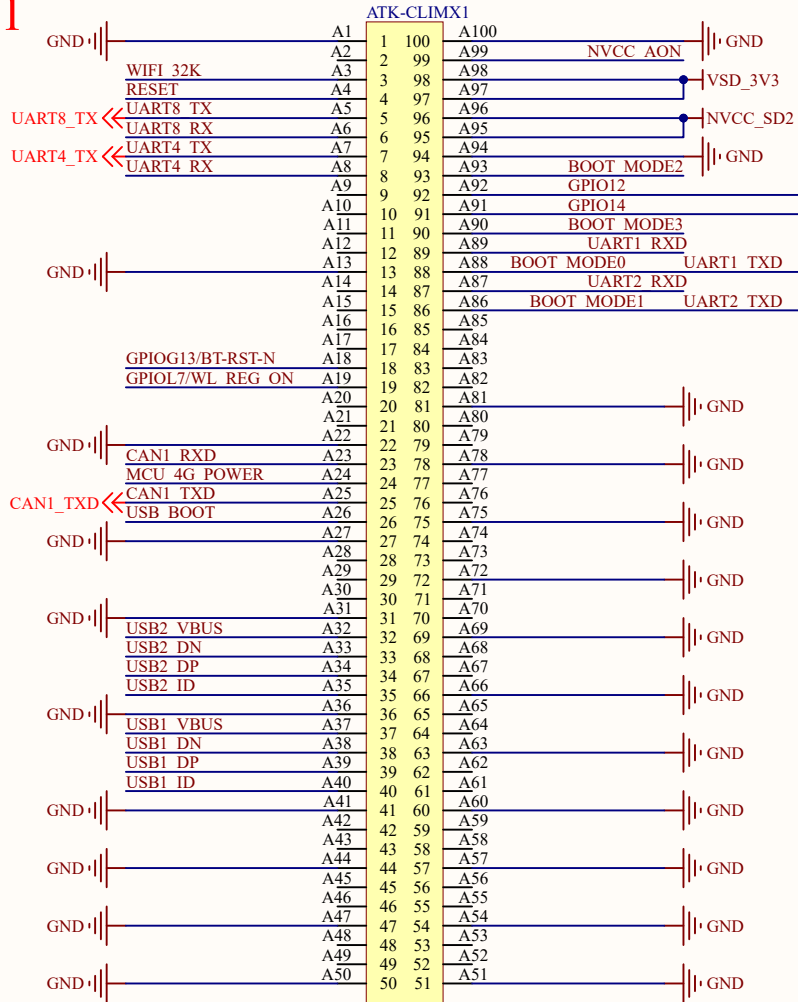

https://item.szlcsc.com/3856579.html?fromZone=1_c_%2522catalog%2522

Title		
Size	Number	Revision
A4		
Date:	2/04/2025	Sheet of
File:	E:\AAAAA\..ATK-CLIMX93B1.SchDoc	Drawn By:

TF Card

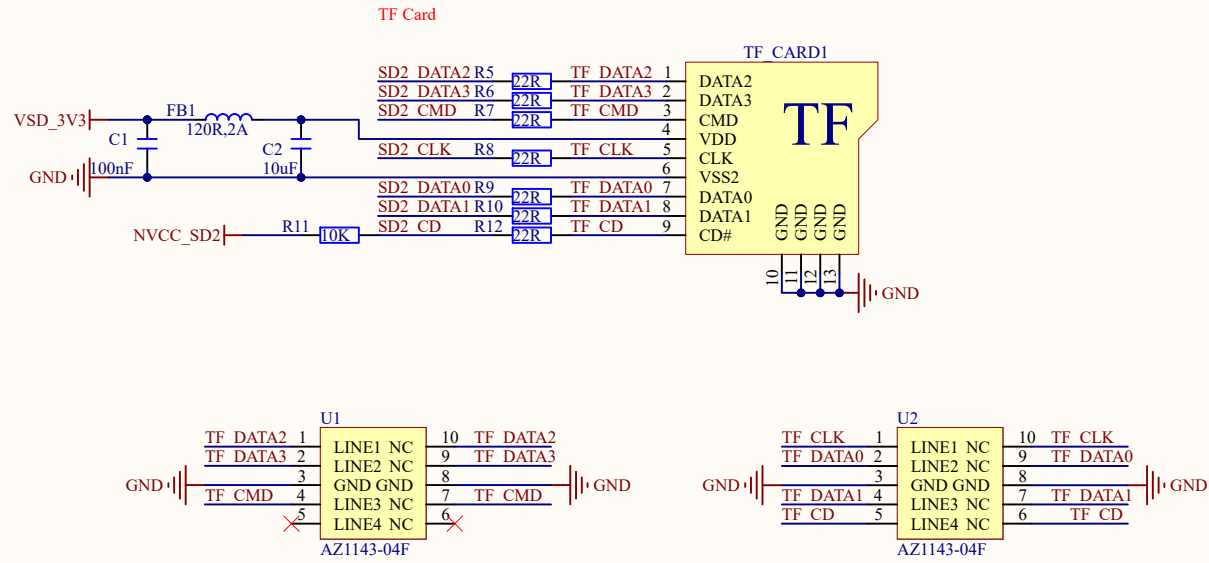

Title		
Size	Number	Revision
A4		
Date:	2/04/2025	Sheet of
File:	E:\AAAAA\..TF Card.SchDoc	Drawn By:

USB_OTG

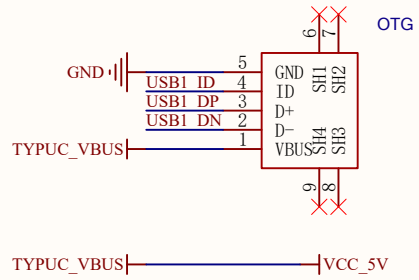

Title		
Size	Number	Revision
A4		
Date:	2/04/2025	Sheet of
File:	E:\AAAAA\..USB_OTG.SchDoc	Drawn By:

USB_UART

USB UART&USB POWER
SYSTEM DEBUG PORT

UART1: CORTEX-A55 CONSOLE
UART2: CORTEX-M33 CONSOLE

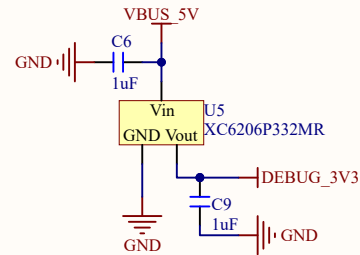
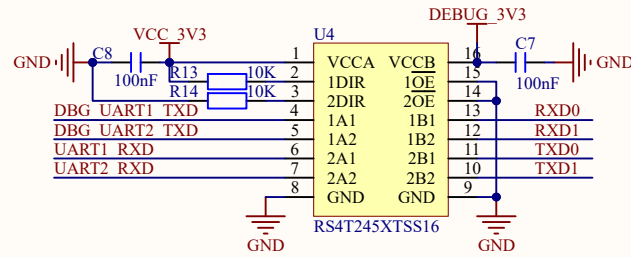
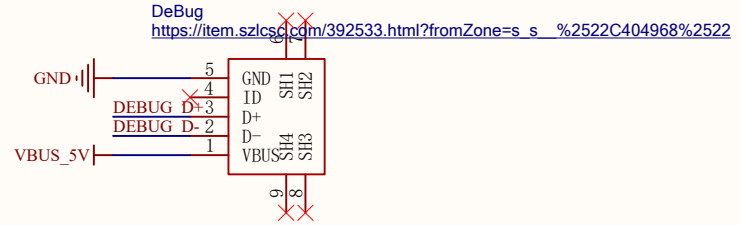
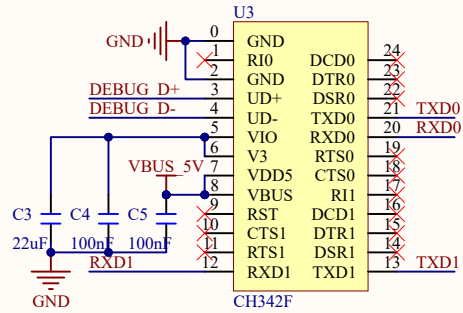

Title		
Size	Number	Revision
A4		
Date:	2/04/2025	Sheet of
File:	E:\AAAAA\..USB_UART.SchDoc	Drawn By:

USB HUB

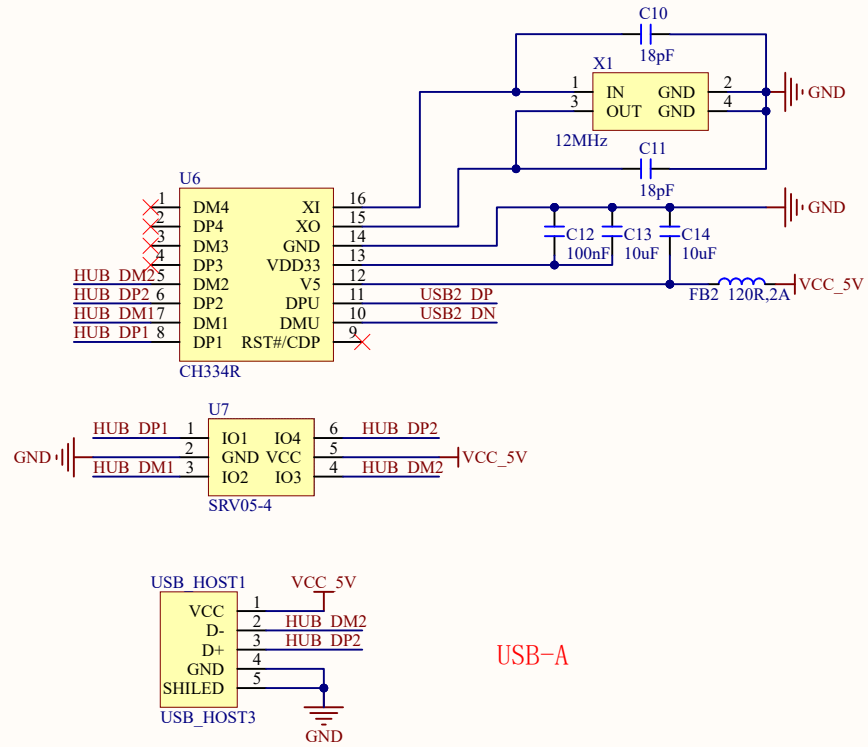

USB-A

Title		
Size A4	Number	Revision
Date:	2/04/2025	Sheet of
File:	E:\AAAAA\..USB HUB.SchDoc	Drawn By:

BOOT_MODE CONFIG

BOOT_MODE1 has pulled 3V3 on the core board, that is, the EMMC boot mode is selected by default

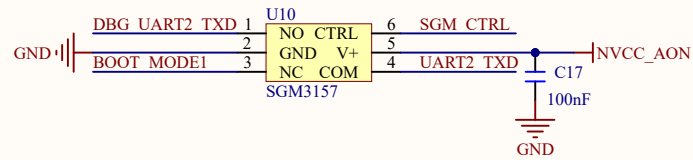
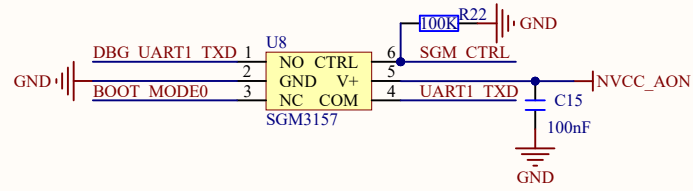
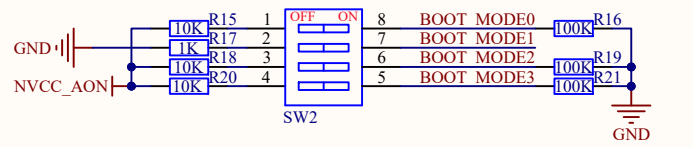

NVCC_AON=3V3

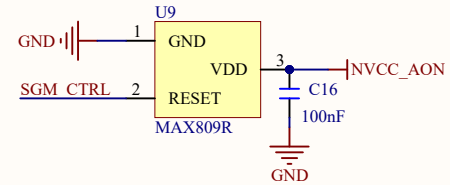

BOOT DEVICE	BOOT CORE	BOOT0	BOOT1	BOOT2	BOOT3
USB	Cortex-A55	1	1	0	0
EMMC	Cortex-A55	0	0	0	0
SD Card	Cortex-A55	1	0	0	0
USB	Cortex-M33	1	1	0	1
EMMC	Cortex-M33	0	0	0	1
SD Card	Cortex-M33	1	0	0	1

0=OFF , 0 is floating signal or grounded

1=ON , 1 is signal with pull-up or pull-down

NOTE: BOOT_MODE1 pull-up 10K Resistor on Core Board default

Title		
Size A4	Number	Revision
Date:	2/04/2025	Sheet of
File:	E:\AAAAA\..BOOT_MODE CONFIG.Sch Drawn By:	

IM948

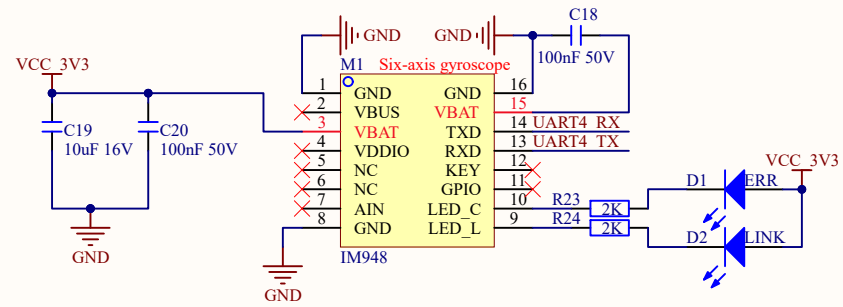

Title		
Size	Number	Revision
A4		
Date:	2/04/2025	Sheet of
File:	E:\AAAAA\..IM948.SchDoc	Drawn By:

POWER

VCC_1V8

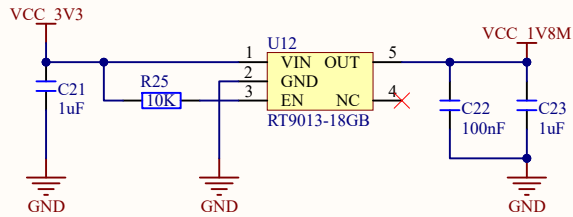

OBD_POWER

VDD5V

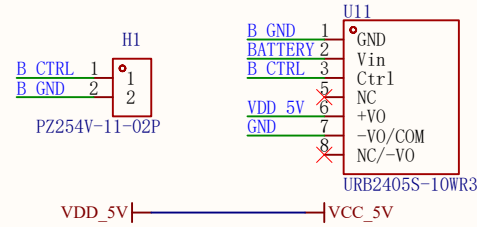

OBD power supply part, the input of this isolated power supply is 9V36V, The output is 5V, the power is 10W, and the voltage of the car is 12V and 24V species, can be compatible. When the voltage of the VDD_5V is greater than that of the MicroUSB VDD_5V power is supplied to the board, otherwise the board is powered from MicroUSB Get power. The function of H1 is to disable the power module and force it MicroUSB power supply.

3V3

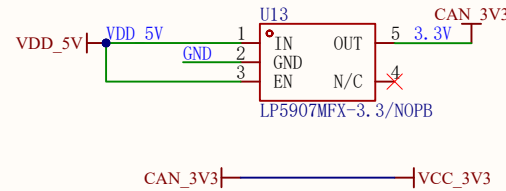

The VDD_5V on the core board outputs 3.3V, electricity through the RT8059 Stream 1A, but I am worried that the power is not enough, so I put another LDO to give USB to CAN power supply.

JTAG

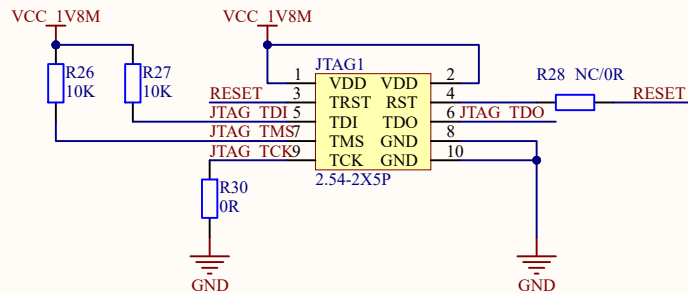

EC800_3V8

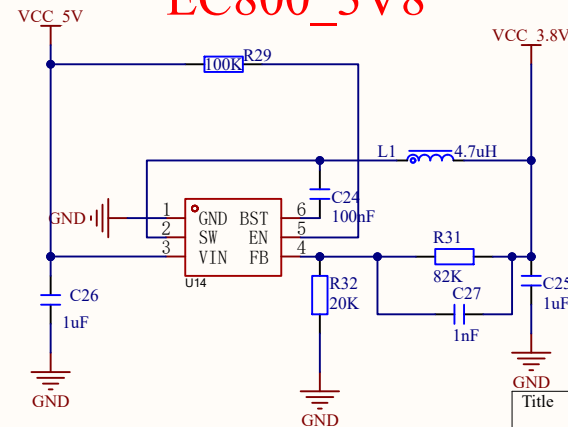

Title		
Size	Number	Revision
A4		
Date:	2/04/2025	Sheet of
File:	E:\AAAAA\..POWER.SchDoc	Drawn By:

DB9_CAN

两路CAN

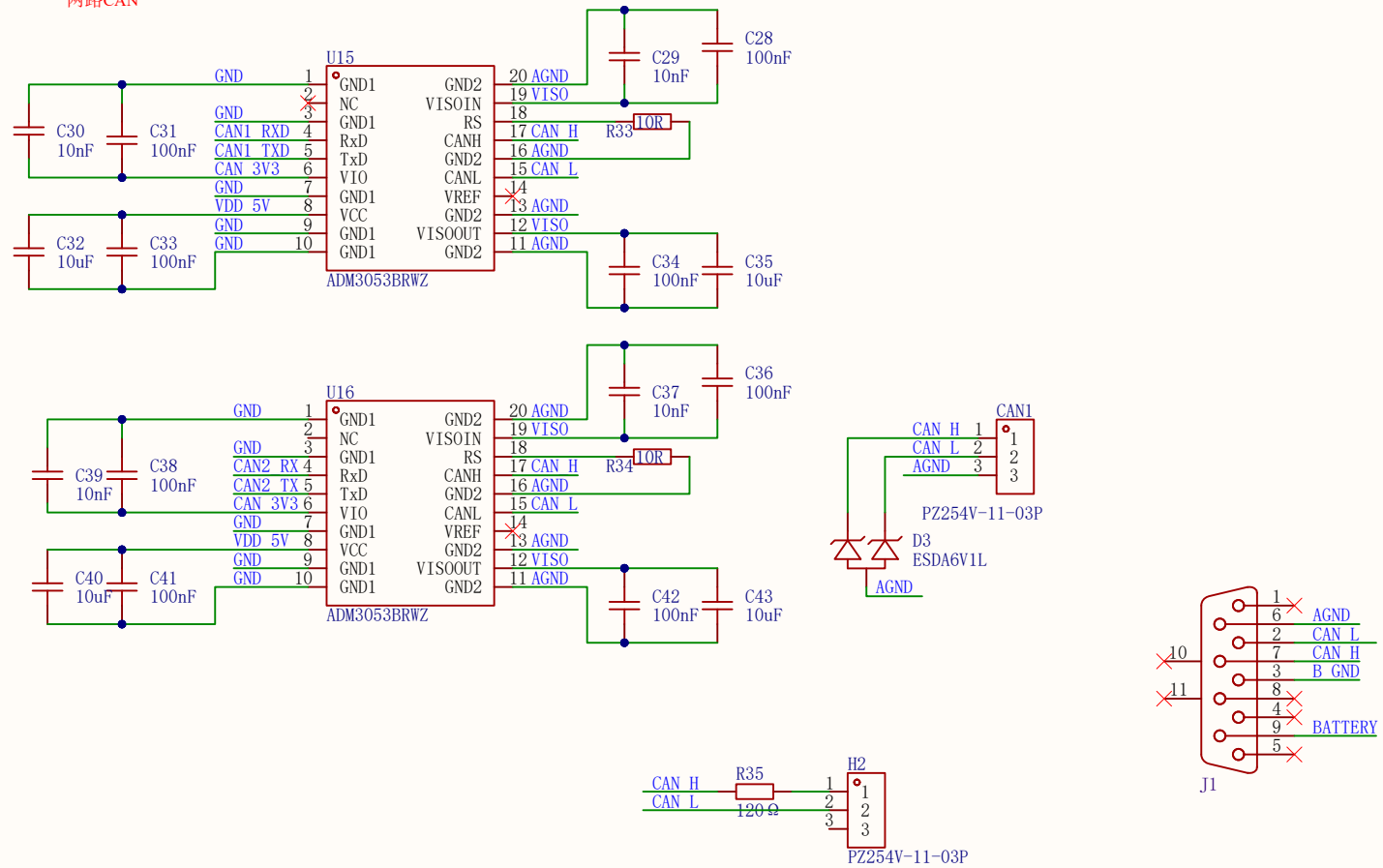

As for the CAN isolation transceiver, I consider isolation
 Directly use the relay to switch the terminal resistor, so volume
 Large power consumption, but the circuit is simple, if you use analog on
 off, the power supply and signal of the analog switch should be isolated,
 The circuit is too complex.

The role of H2 is:
 1,2 When short-circuited: access the terminal resistor, do not use the remote control terminal resistor

Title		
Size A4	Number	Revision
Date:	2/04/2025	Sheet of
File:	E:\AAAAA\..DB9_CAN.SchDoc	Drawn By:

WIFI

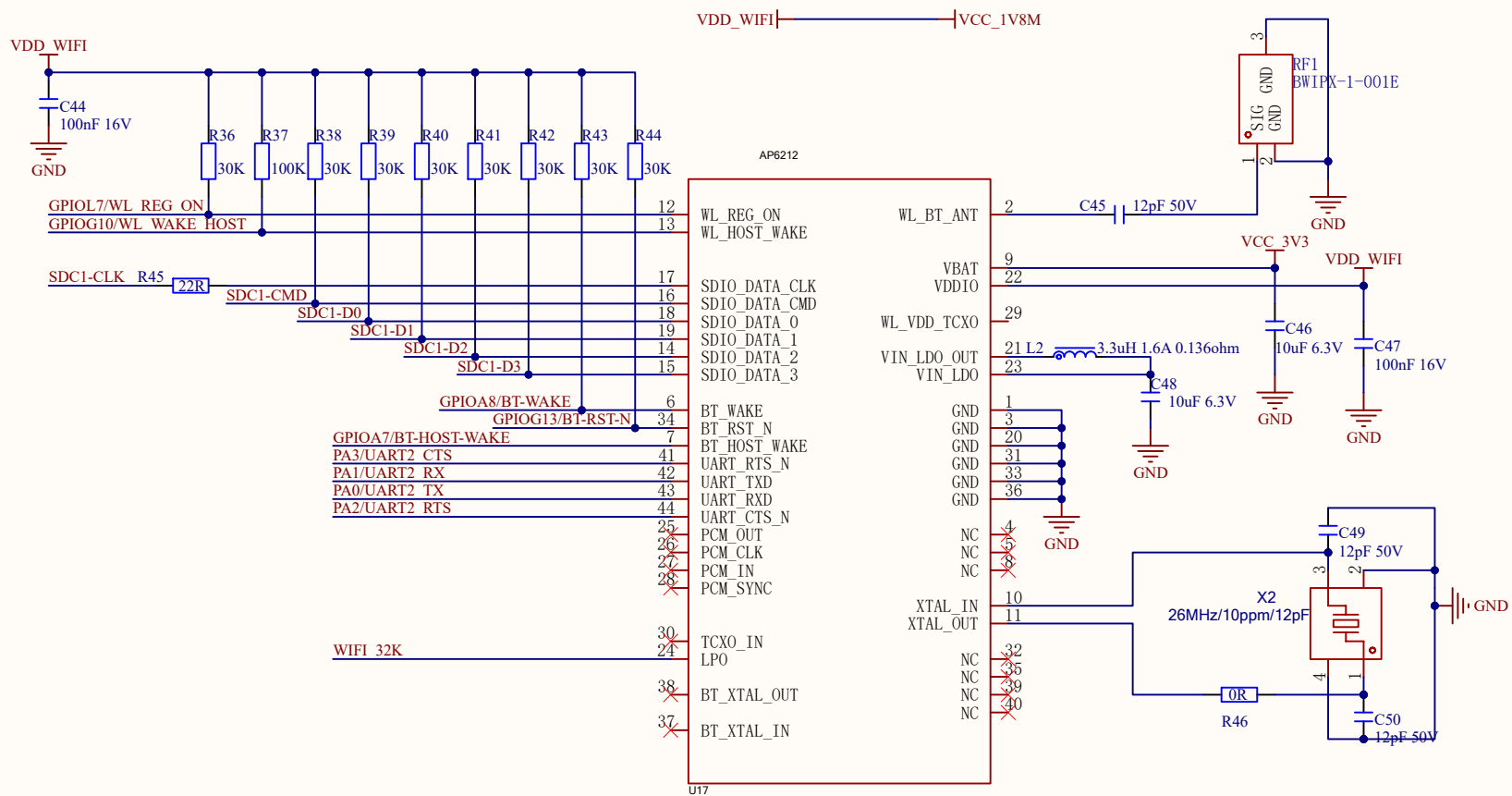

Title		
Size	Number	Revision
A4		
Date:	2/04/2025	Sheet of
File:	E:\AAAAA\..WIFI AP6212.SchDoc	Drawn By:

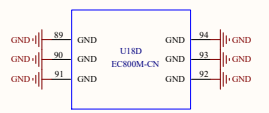
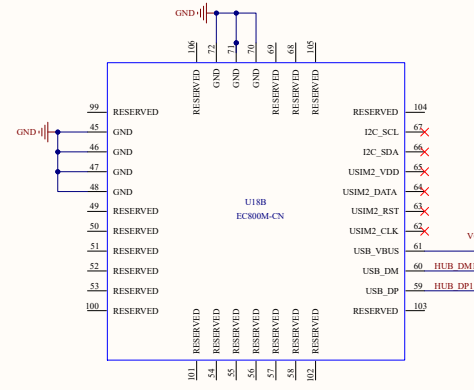
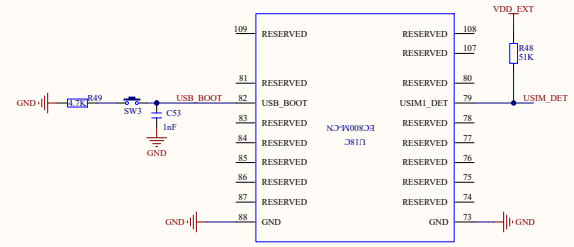
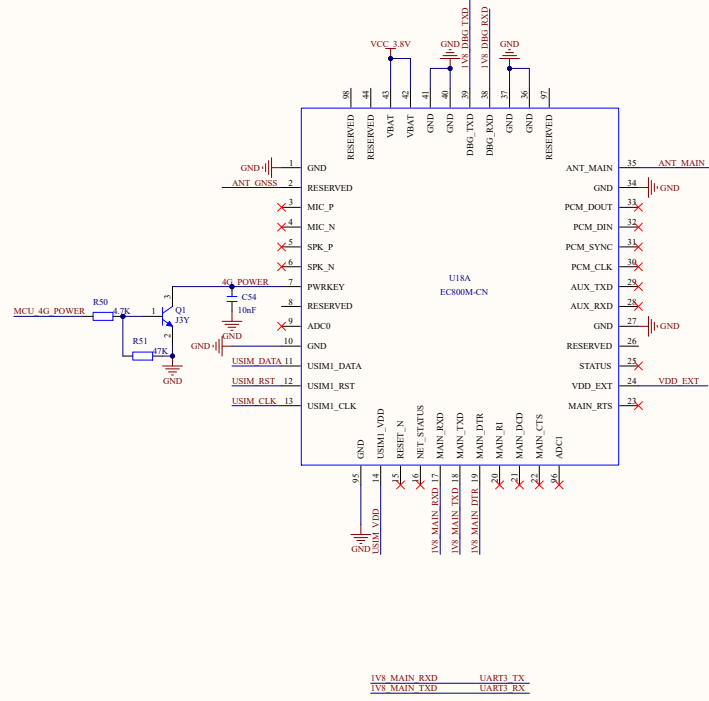
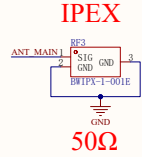
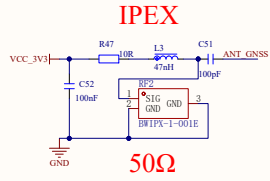

UART Level-shifting Circuit

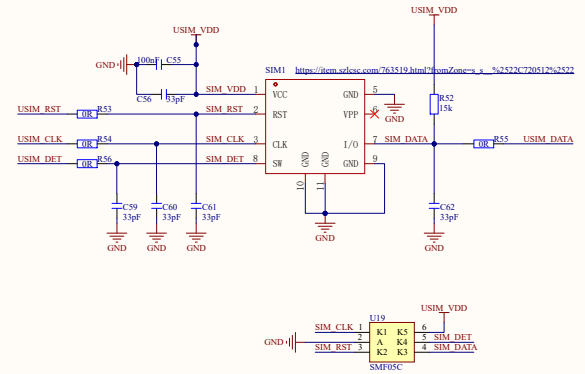
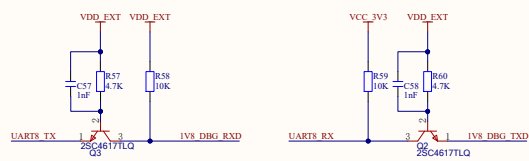

Title		Revision	
Size	A2	Number	
Date	2004/2025	Sheet of	
File	E:\AAAA\4G_EC800M-CN_SchDoc	Drawn By	